



The
Fountainhead
Group, Inc.

PUMPZERO
POWER SPRAYER

Battery-Powered Electric Sprayer

Use and Care Manual



⚠ CAUTION: Read and follow all instructions

Do Not Return This Sprayer To The Store
For Help, Information or Parts, Call : 1-800-311-9903

The Fountainhead Group, Inc.

23 Garden St., New York Mills, NY 13417

1-800-311-9903

www.TheFountainheadGroup.com

Manual No. 183994

Rev A: 12/01/18

ECN18-101

5 1/2" X 8 1/2" Booklet

INTRODUCTION TO SPRAYER

SAFETY PRECAUTIONS

- User must read and understand entire instruction manual before operating this Sprayer.
- Never use flammable or combustible liquids, caustics, acids, or hot water in this Sprayer.
- Always wear appropriate personal protection equipment as instructed by chemical manufacturer when using, preparing, handling, spraying, or disposing of chemicals. This includes at least goggles, gloves, and protective clothing.
- Read and follow all instructions and cautions on label of products used in this Sprayer.
- To reduce risk of battery fire or bursts, use only Fountainhead Group Chargers that are in good condition and have not been damaged.
- Inspect Sprayer, Hose, Shut-off, and Wand, for damage or loose connections before each use.
- Always use replacement parts from the original manufacturer.
- Never attempt to alter Sprayer from original condition.
- Any changes or modifications to the Sprayer not expressly approved by the manufacturer will void the user's authority to operate the Sprayer and void the warranty.
- Do not lift or carry the Sprayer by the Hose, Shut-off valve, or Wand. Carry by the Handle only.
- Only spray when the air is calm (no wind or air movement) to prevent chemical spray from drifting into unintended areas.
- Store the Sprayer, Pump, and Charger indoors in a warm, dry location out of direct sunlight and away from any sources of moisture or intense heat. Do not store Sprayer where freezing temperatures (below 32°F/0°C) will occur. Allowing water to freeze inside the Sprayer may damage the Pump, Seals, Shutoff, or other components, and void the Sprayer warranty.
- Keep the Sprayer and all chemicals out of the reach of children.
- Remove chemicals and thoroughly clean the Sprayer after each use. Failure to clean the Sprayer may cause contamination of subsequent applications, will cause premature Sprayer wear, and void the Sprayer warranty.

About this Sprayer

WARNING: RISK OF FIRE, BURNS, OR ELECTRICAL SHOCK. To reduce the risk of injury, user must read and understand entire instruction manual before operating this Sprayer.

This is an electric-powered compressed-air style tank sprayer that is designed to spray water soluble solutions, such as herbicides, pesticides, and other liquid chemicals typically used for weed prevention, weed remediation, pest control, fertilizing, and watering.

This Sprayer uses an internal rechargeable Lithium-Ion Battery to power an electric air compressor Pump. The PumpZero Electric Pump is designed to provide a more convenient and more consistent alternative to standard manual pumps. It operates by pressurizing the air above the fluid in the Tank, which causes the fluid to be pushed through the Hose, to the Nozzle, and sprayed out. Because the PumpZero Electric Pump operates by pressurizing air in the Tank, it is important that a good air seal is achieved when the Pump is tightened into the Tank.

While actively spraying it is normal for the Pump to turn on and off by itself periodically; it is not expected to run continuously. The Pump will pressurize the air inside the Tank, then turn off and let the air pressure do the work of spraying out the fluid. As the fluid is sprayed out, the air pressure inside the Tank will decrease, eventually causing the Pump to turn on again. Having the Pump turn on and off in this manner allows for longer Battery life and greater Pump longevity, compared to a continuously running Pump.

The PumpZero Electric Pump contains an internal Lithium-Ion Battery. The shipment of Lithium-Ion Batteries is subject to international shipping regulations. Accordingly, the Battery must be in a reduced-charge state for shipping, so the Pump must be charged prior to initial use. As with all products containing Lithium-Ion Batteries, consult your local shipping agent for instructions prior to shipping the Pump.

The PumpZero Electric Pump is equipped with an auto-off feature that turns the Pump off after 2 hours of inactivity. This is to prevent the Battery from being drained if the Pump is left on when the Sprayer is not in use.

ASSEMBLY INSTRUCTIONS

Assemble Hose To Tank

IMPORTANT: Do not attempt to heat or alter hose, hose nut, or barb prior to assembly.

1. Align Hose Barb tabs, push Hose Barb into Tank until it stops (See **Figure A**).
2. Slide Hose Nut into place and turn clockwise to tighten. (See **Figure B**).

NOTE: Do not use tools to tighten Hose Nut.

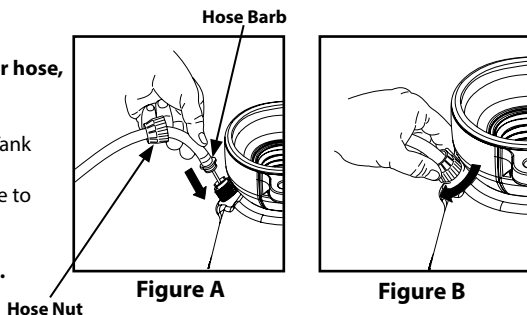

Assemble Wand, Shut-Off & Nozzle

1. Install the Wand onto the Shut-off and tighten the Nut securely. (**Figure C, Step 1**)
2. Install selected Nozzle onto the end of the Wand and tighten securely. (**Figure C, Step 2**)

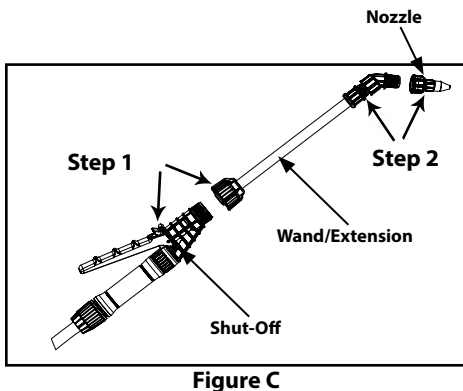

SELECT NOZZLE FROM LIST BELOW

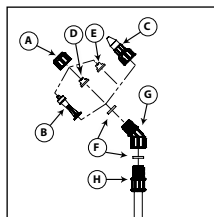

Figure D

- A. Cap Nut
- B. Foaming Nozzle
- C. Adjustable Cone Nozzle
- D. Red High-Volume Fan Nozzle
- E. Yellow Low-Volume Fan Nozzle
- F. Flat Seal
- G. Adapter
- H. Wand





| ADJUSTABLE CONE USES: | FOAMING NOZZLE USES: |
|--|---|
|  <ul style="list-style-type: none"> • Spot spraying in or around flower beds, trees, and shrubs. • Edging along fences, driveways, and walkways. • Killing brush such as poison ivy, poison oak, kudzu and wild blackberry. • Preparing garden beds for planting of ornamentals and vegetables. |  <ul style="list-style-type: none"> • Spot spraying in flower beds, walkways, driveways, and patios, around trees and shrubs. • Edging along fences, driveways and walkways. • Killing brush such as poison ivy, poison oak, kudzu and wild blackberry. |
| RED HIGH VOLUME FAN NOZZLE USES: | YELLOW LOW VOLUME FAN NOZZLE USES: |
|  <ul style="list-style-type: none"> • Lawn replacement. Kill lawn and weeds before planting a new lawn. • Preparing large areas for planting of ornamental and vegetable gardens. |  <ul style="list-style-type: none"> • For precision spraying in confined areas such as gardens and flower beds. |

Figure E

OPERATING INSTRUCTIONS

WARNING: RISK OF FIRE, BURNS, OR ELECTRICAL SHOCK. Use Charger only in a dry, dust-free location free from any flammable or combustible liquids or vapors. Use only with Fountainhead Group Chargers – Other types of Chargers may cause Battery failure resulting in personal injury and damage. Do not short circuit the Charger or Battery terminals. Do not charge damaged Batteries. Do not expose to liquid, vapor, or rain.

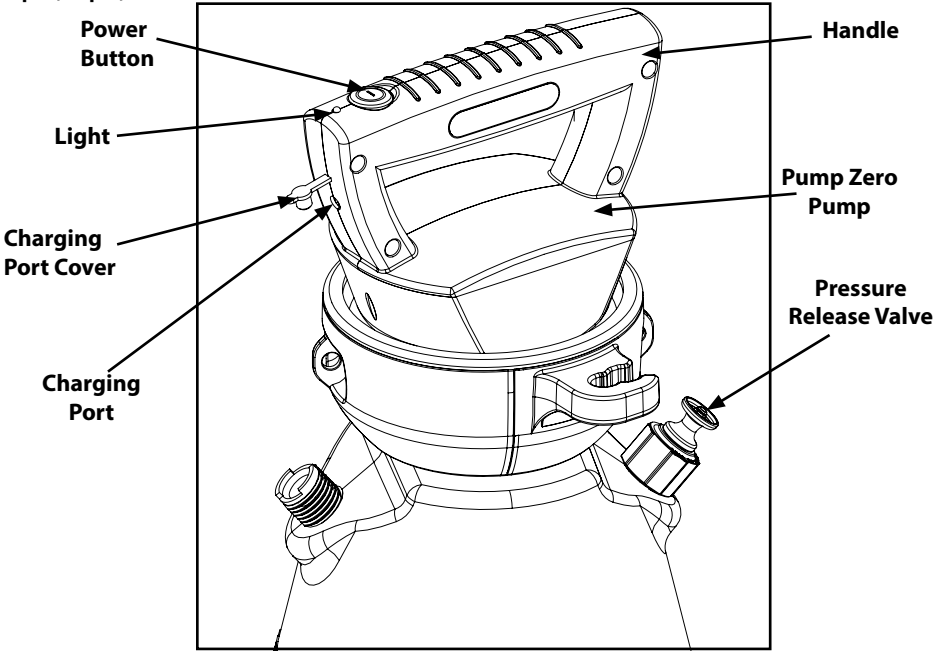

Charging the Pump Internal Battery

1. In a dry, clean location insert the Charger Plug into a standard electrical wall outlet. **See Figure F.** On the end of the Pump handle, remove the rubber Cover to expose the Charging Port. Plug the Charger Cable into the Charging Port on the Pump. The Light on the top of the Pump should start flashing green.

a. The Pump cannot be operated while Charging.

The Pump must be disconnected from the Charger to permit further use.

b. If the light on the Pump flashes red, the Battery is too hot to be safely charged. This can happen when the Battery is used heavily in very hot weather or if the Battery is stored in a very hot location (such as in an enclosed vehicle or storage unit during very hot weather). If this happens the Battery must be allowed to cool before it can be charged.

c. If the light on the Pump flashes red and green alternately, this means the Battery has been damaged and cannot be charged within the safe charging time limit. The internal Battery cannot be serviced, so the Pump must be replaced.

2. Ensure the Pump and Charger are placed where they will not be exposed to liquids, falls or other sources of damage for the duration of the charging period.

3. When charging is complete the light will remain green and stay on constantly. Charging time will vary depending on Battery condition at the start of charging. Charging time should not exceed 3 hours.

4. Remove the Charger Cable from the Pump once charging is complete. Pumps should not be connected to the Charger during long periods of storage. To ensure optimal Battery life the Pump should be charged at least once every 3 months when not in use.

5. Reinsert the rubber Cover into the Charging Port to protect it.

6. Unplug the Charger from the electrical wall outlet when not in use.

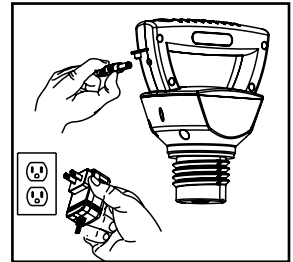

Figure F

OPERATING INSTRUCTIONS

Filling the Sprayer

WARNING: RISK OF DEATH, PERSONAL INJURY AND/OR PROPERTY DAMAGE FROM IMPROPER CHEMICAL USE OR MIXTURE. Never use flammable or combustible liquids, caustics, acids, or hot water in this Sprayer. Spraying flammable or combustible liquids can create combustible fumes that could be ignited by the electrical system in the Sprayer, causing an explosion. Always refer to chemical manufacturer instructions for proper mixture. Always wear appropriate personal protection equipment as instructed by chemical manufacturer when using, preparing, handling, spraying, or disposing of chemicals. This includes at least goggles, gloves, and protective clothing.

CAUTION: RISK OF DAMAGE TO INTERNAL COMPONENTS. Use of chemicals other than water based or water soluble solutions may damage the Sprayer and will void the warranty.

1. Ensure that the Pump is turned OFF (Light is OFF).
2. Pull up on the knob of the Pressure Release Valve until all the pressure is released from the tank (See Figure G).

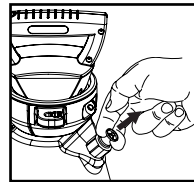

Figure G

2. Turn the Pump handle counterclockwise to remove the pump (See Figure H).
3. Fill the Tank to the desired level. See fill markings on side of Tank. (Always refer to chemical manufacturer for proper mixture).
4. Install the Pump into the Tank opening and turn clockwise until tightly sealed against the Tank (See Figure I).

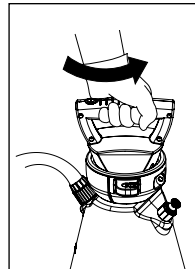

Figure H

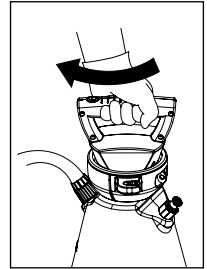

Figure I

Powering-On and Spraying:

WARNING: RISK OF UNINTENDED SPRAYING AND CHEMICAL EXPOSURE. Ensure that the Shut-off is in the closed position (Lever released) before pressing the Power Button. The Sprayer will spray if the Shut-off is open (Lever depressed) when the power is turned ON. Only spray when the air is calm (no wind or air movement) to prevent chemical spray from drifting into unintended areas.

OPERATING INSTRUCTIONS CONTINUED

1. The PumpZero Pump must be charged for the Sprayer to operate. See *Charging the Pump Internal Battery*.
2. Press the Power Button to turn on the Pump and begin pressurizing the Tank.
 - a. The Light on the top should turn green and an audible hum should be heard, indicating the Pump is running and is pressurizing the Tank.
 - b. The Pump will turn off once the Tank is pressurized, which may take 30 seconds to several minutes depending on the size of the Tank and the amount of fluid in it.
 - c. It is permissible to start spraying before the Tank is fully pressurized, but in order to avoid a sub-optimal spray pattern it is recommended to wait at least 20 seconds to allow some pressure to build in the Tank.
3. Aim the Wand in the desired direction of spraying and depress the Shut-off Lever. (See Figure K)
4. For continuous spraying, depress the Lever and rotate the Lock to hold the Lever in the depressed position.
5. Unlock, if needed, and release the Shut-off Lever to stop spraying.
6. To turn off the Sprayer press the Power Button. The Light will turn OFF.
7. Note that the Tank is still pressurized even though the Pump has been turned OFF.
8. Always remove any chemical, and clean the Sprayer when finished using. See *Cleaning & Storage*.

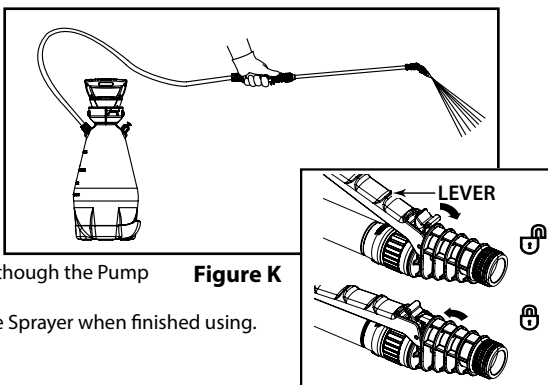

Low Battery Indicator

The Pump is equipped with a Low Battery Indicator. When the Pump is operating, the Light on the top of the Pump will change from steady green to flashing green when the Battery has 25% of charge remaining. This is typically enough to finish spraying the current Tank of fluid and one additional Tank. The Pump should then be charged. See *Charging the Pump Internal Battery*. When the Battery is completely out of charge the Light will turn OFF and the Pump will not operate.

SPRAYER MAINTENANCE

Cleaning & Storage

WARNING: RISK OF PERSONAL INJURY DUE TO CHEMICAL EXPOSURE. Always wear appropriate personal protection equipment as instructed by chemical manufacturer when using, preparing, handling, spraying, or disposing of chemicals. This includes at least goggles, gloves, and protective clothing. Prior to performing maintenance always depressurize Sprayer by turning off the Pump and operating the Pressure Release Valve until no pressure remains in the Tank.

CAUTION: RISK OF DAMAGE TO INTERNAL COMPONENTS. Failure to properly rinse out the Sprayer may allow chemical residue build-up that can clog or damage the Filters, Pump, Shut-off, Wand, and Nozzle. Chemical residue build-up can also contaminate subsequent applications. Leaving chemical liquids in the Sprayer when not in use can lead to premature Sprayer wear. Never store Sprayer with chemical in any part of the Sprayer.

SPRAYER MAINTENANCE CONTINUED

Cleaning and Storage Continued:

1. Turn off the Pump by pressing the Power Button. The light on the top of the Pump should turn off.
2. Operate the Pressure Release Valve on the side of the Tank by gently pulling it outward until the air inside the Tank stops flowing out.
3. Remove the Pump from the Tank by turning it counter-clockwise. Avoid placing the Pump down where it may become contaminated with dirt, grass clippings, or debris that could later enter the Tank.
4. Empty any extra chemical from the Tank into a suitable container for later use or disposal according to chemical manufacturer's instructions.
5. Use clean water to thoroughly rinse and empty the Tank until all chemical and residues are removed.
6. Use a wet cloth to wipe the bottom of the Pump until all chemical and residues are removed. Do not rinse the Pump with a hose or submerge in water, as water will enter the Housing, damaging the electrical components, rendering the Pump non-functional, and voiding the warranty.
7. Add approximately 1 quart [1 liter] of clean water to the Tank.
8. Attach the Pump to the Tank and tighten firmly.
9. Press the Power Button so the Pump will pressurize the Tank.
10. With clean water in the clean Tank, spray water through the Hose, Shutoff, Wand, and Nozzle for at least 30 seconds to rinse them out. Failure to rinse out the Hose, Shutoff, Wand, and Nozzle may allow chemical residue build-up that can clog or damage the components. After heavy use rinsing the Nozzle may not be enough to remove residue. The Nozzle may need to be cleaned with a small brush.
11. Press the Power Button to turn off the Pump.
12. Operate the Pressure Release Valve on the side of the Tank to release pressure.
13. Remove the Pump. Avoid placing the Pump down where it may become contaminated with dirt, grass clippings, or debris that could later enter the Tank.
14. Open the Shut-off (depress Lever) to drain any remaining water from the Hose, Shut-off, and Wand.
15. Empty out any remaining water from the Tank.
16. Allow the Sprayer to dry. This is best done by hanging the Tank upside down to let it drain.
17. Once the Sprayer is dried turn the Sprayer upright and loosely assemble the Pump to the Tank to prevent debris from entering the Tank.
18. Store the Sprayer, Pump, and Charger indoors in a warm, dry location out of direct sunlight and away from any sources of moisture or intense heat. Do not store Sprayer where freezing temperatures (below 32°F/0°C) will occur. Allowing water to freeze inside the Sprayer may damage the Pump, Seals, Shutoff, or other components, and void the Sprayer warranty.
19. To ensure optimal Battery life the Battery should be charged at least once every 3 months when not in use. See *Charging the Pump Internal Battery*.

SERVICING INSTRUCTIONS

Shut-off Maintenance (Smith Pro)

WARNING: Prior to performing maintenance always depressurize Sprayer by pressing the Power Button to turn power OFF and then operating the Pressure Release Valve until all air pressure in the Tank has been released.

1. Unscrew the Handle from the Shut-off Assembly. (See Figure L)
2. Remove the Filter from the Shut-off Assembly.
3. Clean any debris from inside the handle, Shut-off Assembly, or the Filter by rinsing with cool, clean water.
4. Reassemble the components as shown and tighten all connections securely.

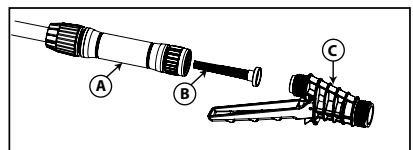

Figure L

- A. Handle**
- B. Filter**
- C. Shut-off Assembly**

SERVICING INSTRUCTIONS CONTINUED

Nozzle Maintenance

WARNING: Prior to performing maintenance always depressurize Sprayer by pressing the Power Button to turn power OFF and then operating the Pressure Release Valve until all air pressure in the Tank has been released.

1. If Nozzle clogs, remove and disassemble the Nozzle assembly.
2. Clean the openings of any obstructions or residue. Do not use sharp tools that could scratch or damage the Nozzle as spray pattern could be affected.

PumpZero Pump Maintenance

The Pump Zero Pump does not require regular maintenance beyond charging and normal cleaning. See *Charging the Pump Internal Battery* and *Cleaning & Storage*.

COMPLIANCE INFORMATION

FCC Compliance:

This device complies with part 15 of the FCC Rules. Operation is subject to the following two conditions: (1) This device may not cause harmful interference, and (2) this device must accept any interference received, including interference that may cause undesired operation.

Note: This equipment has been tested and found to comply with the limits for a Class B digital device, pursuant to part 15 of the FCC Rules. These limits are designed to provide reasonable protection against harmful interference in a residential installation. This equipment generates, uses and can radiate radio frequency energy and, if not installed and used in accordance with the instructions, may cause harmful interference to radio communications. However, there is no guarantee that interference will not occur in a particular installation. If this equipment does cause harmful interference to radio or television reception, which can be determined by turning the equipment off and on, the user is encouraged to try to correct the interference by one or more of the following measures:

- Reorient or relocate the receiving antenna.
- Increase the separation between the equipment and receiver.
- Connect the equipment into an outlet on a circuit different from that to which the receiver is connected.
- Consult the dealer or an experienced radio/TV technician for help.

Canada IC:

CAN ICES-3 (B)/NMB-3(B)

TROUBLESHOOTING

| TROUBLE | LOOK FOR | REMEDY |
|---|--|---|
| Sprayer will not turn on when Power Button is pressed (no audible hum of the pump.) | <ol style="list-style-type: none"> 1. Battery not charged. Light does not turn ON. 2. Pump is damaged, over heated, or non-functional. Visually inspect the Pump for damage. Use the Charger to diagnose any Battery problem. See <i>Charging the Pump Internal Battery</i>. 3. Tank is already pressurized so the Pump has turned off automatically. 4. Pump is connected to Charger. | <ol style="list-style-type: none"> 1. Charge Pump if no light is ON. See <i>Charging the Pump Internal Battery</i>. 2. Replace Pump if damaged or non-functional. Allow Battery to cool if overheated. 3. Open the Shut-off (depress Lever) to see if the Sprayer starts spraying. 4. Disconnect Charger. |
| Sprayer turns on (audible hum of pump heard) but will not spray. | <ol style="list-style-type: none"> 1. No liquid in Tank. 2. Shut-off clogged. 3. Nozzle clogged. 4. Pump is not tightened to Tank, leaks at Seal. | <ol style="list-style-type: none"> 1. Add liquid to Tank. See <i>Filling the Sprayer</i>. 2. Clean Shut-off. See <i>Shut-off Maintenance</i>. 3. Clean Nozzle. See <i>Nozzle Maintenance</i>. 4. Tighten Pump to Tank. |
| Sprayer turns on but only sprays at low pressure. | <ol style="list-style-type: none"> 1. Tank not yet pressurized. 2. Air leaking from Tank at Seal. 3. Tank Seal or Seal surfaces are damaged. 4. Shut-off clogged. 5. Nozzle clogged. | <ol style="list-style-type: none"> 1. Allow time for Pump to pressurize Tank (at least to 20 seconds). 2. Tighten Pump to Tank. 3. Replace Tank Seal. 4. Clean Shut-off. See <i>Shut-off Maintenance</i> 5. Clean Nozzle. See <i>Nozzle Maintenance</i>. |
| Hose Leaks at Tank connection. | <ol style="list-style-type: none"> 1. Cracked, swollen or faulty Hose. 2. Damaged connection. | <ol style="list-style-type: none"> 1. Replace Shut-off Assembly. 2. Replace Shut-off Assembly. |
| Hose Leaks at Shut-off. | <ol style="list-style-type: none"> 1. Cracked, swollen or faulty Hose. 2. Damaged connection. | <ol style="list-style-type: none"> 1. Replace Shut-off Assembly. 2. Replace Shut-off Assembly. |
| Nozzle drips when Shut-off Lever is released. | <ol style="list-style-type: none"> 1. Dirt or debris in Shut-off. 2. Damaged O-Ring or Seal in Shut-off. | <ol style="list-style-type: none"> 1. Clean Shut-off Assembly. 2. Replace Shut-off Assembly. |
| Nozzle Tip leaks | <ol style="list-style-type: none"> 1. Flat Seal missing. 2. Flat Seal damaged. | <ol style="list-style-type: none"> 1. Install Flat Seal behind Nozzle Tip. See <i>Assemble Wand, Shut-off and Nozzle</i>. 2. Replace Flat Seal. |

TROUBLESHOOTING

| TROUBLE | LOOK FOR | REMEDY |
|--------------------------|--|--|
| Poor Spray Pattern | <ol style="list-style-type: none"> 1. Tank is not pressurized. 2. Nozzle partially clogged. 3. Nozzle damaged. 4. Shut-off clogged. | <ol style="list-style-type: none"> 1. Turn on Pump. 2. Clean Nozzle. See <i>Nozzle Maintenance</i>. 3. Replace Nozzle. 4. Clean Shut-off. See <i>Shut-off Maintenance</i>. |
| Battery will not Charge. | <ol style="list-style-type: none"> 1. Charger not plugged into outlet. 2. No lights illuminated on Pump. Charger plugged into outlet. 3. No lights illuminated on Pump. Charger plugged into outlet, outlet functioning. 4. Red light continues flashing on Pump (Battery temperature too high for safe charging). 5. Red and Green lights flash alternately on Pump (Battery cannot be charged). | <ol style="list-style-type: none"> 1. Plug Charger into outlet. 2. Check that outlet is functioning. 3. Replace Charger. 4. Allow Pump to cool. 5. Replace Pump. |

KITS, PARTS & ACCESSORIES

DESCRIPTION

| Key # | Part # | Description |
|-------|---------|---|
| 1 | 184175 | PUMP, CHARGER & GASKET |
| 2 | 178039V | GASKET (REPLACEMENT, VITON) |
| 3 | 181845 | WAND 14" POLY |
| 4 | 181843 | WAND 18" POLY |
| 5 | 181824 | WAND 21" POLY |
| 6 | 182112 | WAND 21" STAINLESS STEEL |
| 7 | 183173 | HOSE & SHUTOFF (1& 2 GAL) |
| 8 | 183174 | HOSE & SHUTOFF (3 GAL) |
| 9 | 181869 | POLY NOZZLE KIT |
| 10 | 181870 | BRASS NOZZLE KIT |
| 11 | 182902 | 3-WAY NOZZLE (REPLACEMENT, VITON, BLACK) |
| 12 | 181910 | SHUT OFF SERVICE KIT |
| 13 | 182495 | PRESSURE RELEASE VALVE (REPLACEMENT, VITON) |
| 14 | 181080 | SHOULDER STRAP |

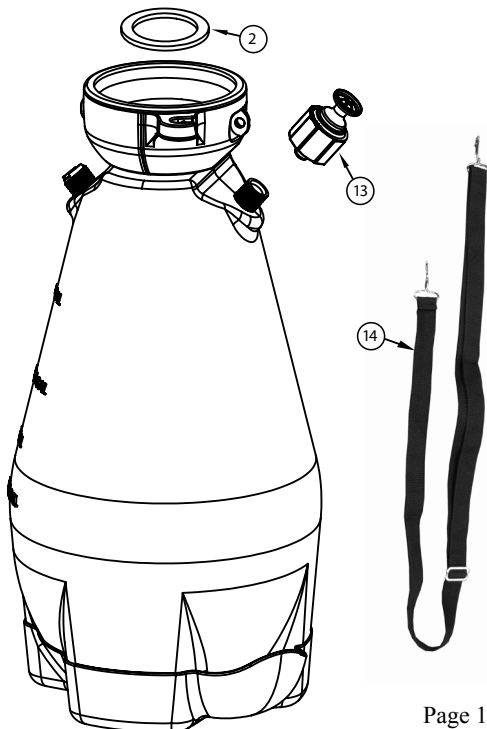
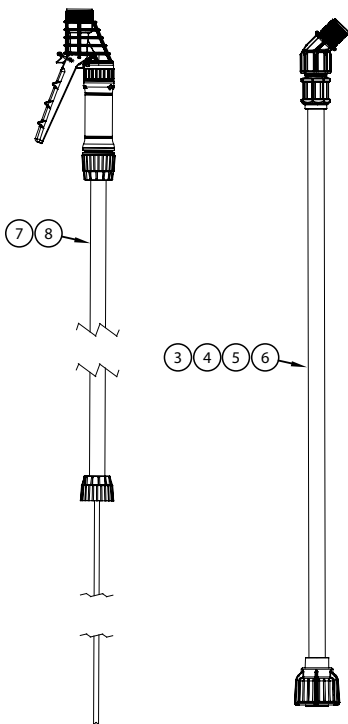
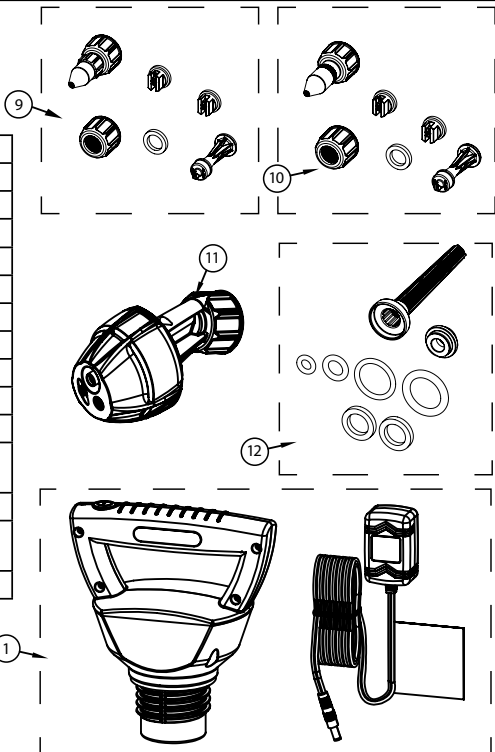

SERVICE KITS, PARTS & ACCESSORIES ARE AVAILABLE BY CONTACTING

The Fountainhead Group, Inc. - Customer Service Center

Monday - Friday 8 A.M. - 5 P.M., EST

Toll Free: 1-800-311-9903

or

e-mail: Info@TheFGI.com

or

Access online at: www.TheFountainheadGroup.com